

ASSEMBLY INSTRUCTIONS

COFFE TABLE

(ITEM # 122)

DIMENSION

L.40" x W.19" x H.14"

COMPONENT AND HARDWARE LIST

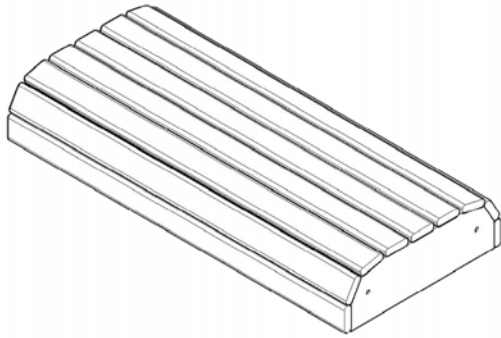

A. TOP SECTION : 1 pcs



B. LEG: 6 pcs

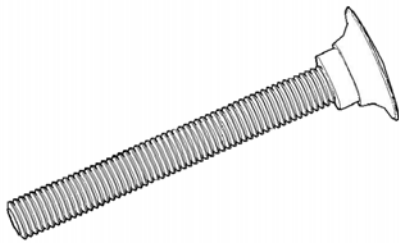

01. BOLT 5/16 x 2.25 inch : 6 pcs

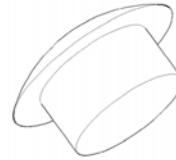

02. SKREW CAP 5/16 inch : 6 pcs

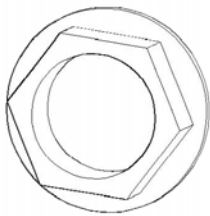

03. FLANGE NUT 5/16 inch : 6 pcs

PART OF PRODUCT

